

S. H. ROPER.  
HOT AIR ENGINE.

No. 38,866.

Patented June 9, 1863.

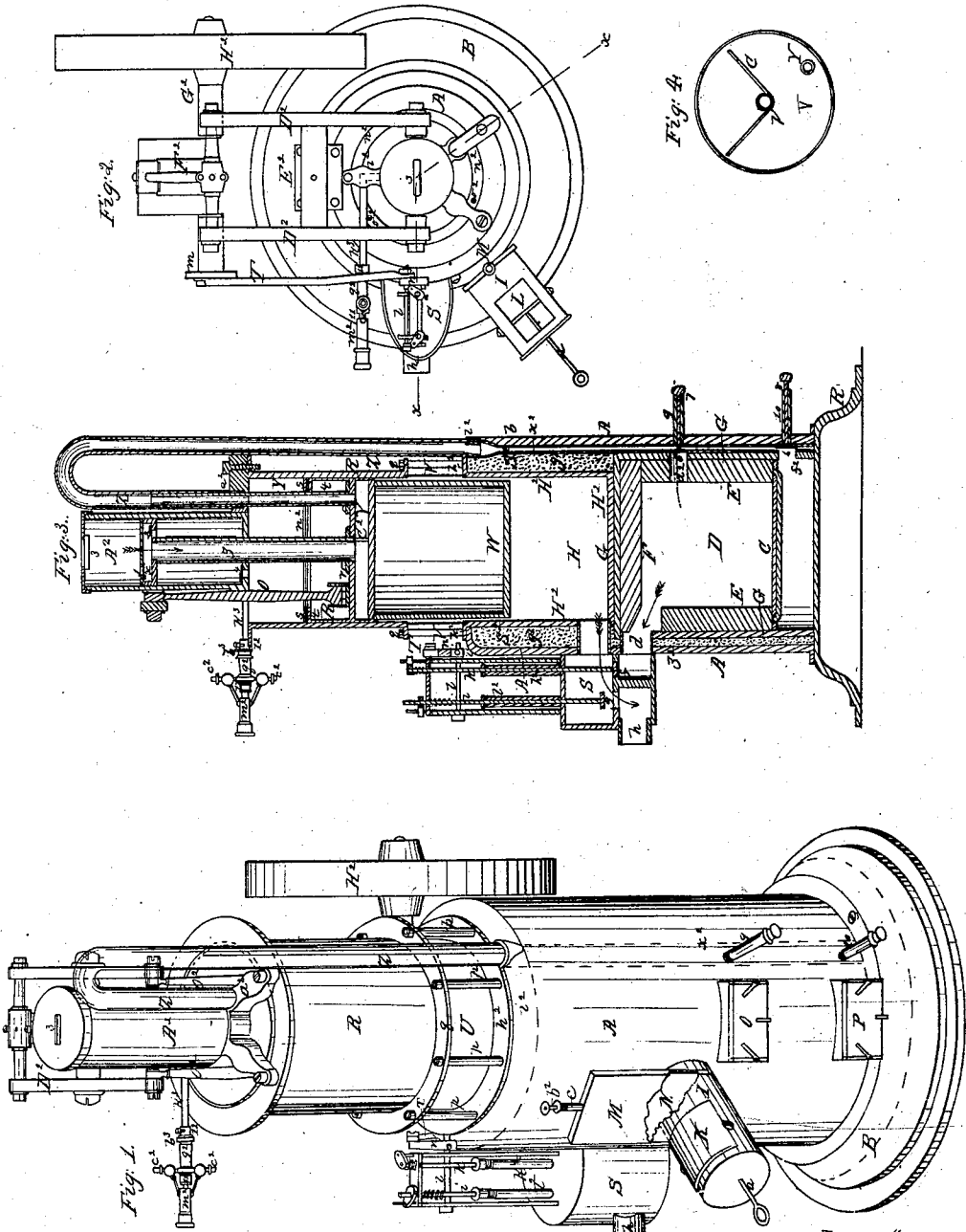

Witnesses.  
J. B. Laughan  
J. H. [Signature]

Inventor/  
Sylvester H. Roper  
By his Attorney  
Sam. Cooper

# UNITED STATES PATENT OFFICE.

SYLVESTER H. ROPER, OF BOSTON, MASSACHUSETTS, ASSIGNOR TO ELMER TOWNSEND, OF SAME PLACE.

## IMPROVEMENT IN HOT-AIR ENGINES.

Specification forming part of Letters Patent No. 38,866, dated June 9, 1863.

*To all whom it may concern:*

Be it known that I, SYLVESTER H. ROPER, of Boston, in the county of Suffolk and State of Massachusetts, have invented certain Improvements in Hot-Air Engines, of which the following is a full, clear, and exact description, reference being had to the accompanying drawings, making part of this specification, in which—

Figure 1 is a perspective view; Fig. 2, a plan; Fig. 3, a vertical section upon the line *xx* of Fig. 2; Fig. 4, an underneath view of the hollow piston V, the bottom plate being removed to show the deflecting-plate within.

The body or exterior casing, A, rests upon the base B.

The fire-box D is made of a single casting, G, thus avoiding all joints at which leakages might occur, and to protect the iron from the intense heat of the fire the box is surrounded upon the inside with fire-brick or soapstone, E. The upper plate of the casting G is also protected by a slab or plate of soapstone or fire-brick, F, which effectually screens it from the direct action of the fire.

The cylinder is divided into a lower portion, H, and an upper portion, R. The lower portion is formed of a single casting, H<sup>2</sup>, and is inserted at the top of the casing A, the flange *h*, of the casting resting upon the top *i*<sup>2</sup> of the casing A. The space *g*<sup>2</sup>, between the casting and the casing, is then filled with calcined plaster or some equivalent non-conducting substance. This may be done by inverting the casting and placing the casing over it. The lower casting, G, is then placed with its upper plate upon the lower plate, H<sup>2</sup>, of the cylinder, and the space *g*, between the lower casting and the casing, is also filled with plaster. The entire furnace, as well as that portion of the cylinder which is exposed to the heat, is thus surrounded by a non-conducting substance, by which great economy of heat is effected.

The fuel is fed to the furnace in the following manner: I is a cylinder, having a tight-fitting cover, K, which is secured by clamps or screws in any well-known manner to its seat. The cover shown in Fig. 1 is curved, but in practice it is preferable to make them flat, as they are more easily fitted and made tight than when curved. Within this cylinder

is a piston, L, having a rod *a*, which passes through a stuffing-box in the end of the cylinder, and is furnished with a handle by which the piston may be manipulated. From the top of the cylinder rises a narrow chamber, M, in which slides a disk or plate valve, N, a portion of which is seen in Fig. 1, the cylinder and chamber being broken away to show it. The valve N is manipulated by means of a rod, *b*<sup>2</sup>, rising from the plate, which passes through a stuffing-box, *c*, in the top of the chamber M. When the valve is down, as represented in Fig. 1, it cuts off the communication between the furnace and the cylinder. When the fire is to be replenished, the cover K is removed, and the piston L is drawn back. The coal is then put into the cylinder. The cover is replaced, the valve N is raised, and the coal is forced into the furnace by means of the rod *a*.

O is a tight-fitting door, through which the furnace may be fed by hand, and P a similar door to the ash-pit. The heated air from the furnace is admitted to the cylinder through a valve-chest, S, and valve *f*, and is exhausted through the valve *g* and pipe *h* into a chimney or other suitable conduit, there being a passage, *d*, fitted air-tight to the furnace and the valve-chest, and a corresponding opening in the fire-brick lining. The passage from the valve-chest to the cylinder is also fitted air-tight at each end. The valve-rods *i* and *k*, which pass through stuffing-boxes *l*<sup>2</sup> *k*<sup>2</sup>, are actuated in a well-known manner by tappets upon a rock-shaft, *l*, which is set in motion by an eccentric or by a crank upon the shaft G<sup>2</sup>, one end of the rod T being connected with the crank and the other with the arm *n* upon the rock-shaft.

The most serious difficulty thus far encountered in the construction and operation of hot-air engines arises from the great heat to which the cylinder and piston are exposed, and the consequent destruction of the oil used for lubricating them. To remedy this inconvenience, I adopt the following construction: The upper portion, R, of the cylinder, or that portion which comes in contact with the piston, is isolated from the lower portion, which receives the heated air, a cylinder, U, of thin sheet metal being interposed between them. This cylinder is secured between the flanges *h*<sup>2</sup> and *g*, and the whole are held together by the

bolts  $p$ . The cylinder  $U$ , being made as thin as may be and stand the pressure within, and being constantly refrigerated by radiation and by exposure to the atmosphere, transmits only a trifling amount of heat to the cylinder  $R$ , which thus remains constantly so cool as not to destroy the oil used to lubricate it. The piston  $V$  is hollow, and has an open cylinder  $t$ , projecting above its upper plate,  $r$ , a ring of packing,  $s$ , being secured to the upper edge of the cylinder by a metallic ring,  $n^2$ , and screws  $o^2$ . Beneath the piston  $V$  is the prolongation  $W$ , which fits loosely in the cylinder and descends on the downstroke to near the bottom of the chamber  $H$ .

For the purpose of more completely cooling the piston, the air for driving the engine is all passed through it on its way to the fire-box by the following means: Above the cylinder, and secured to the top thereof by screw bolts or otherwise, is the air-pump  $A^2$ , in which works the piston  $x$ , the rod  $z$  of which is hollow and is attached to the upper plate,  $r$ , of the piston,  $V$ . The piston  $x$  is hollow, and has two flap-valves, 1 and 2, opening inward. The upper head of the air-pump has a valve, 3, opening downward, and the lower head a valve, 4, opening upward. By means of the hollow rod  $z$  the cavity in the piston  $V$  is connected with the cavity in the piston  $x$ . A pipe,  $Y$ , extending up from the cavity in the piston  $V$ , slides air-tight within a stationary pipe,  $Z$ , rising from the base  $a^2$  of the air-pump. The pipe  $Z$  is bent down and enters a passage,  $x^2$ , passing down within the casting  $A$ . From this passage there are two pipes,  $d^2$  and  $f^2$ , leading the one to the fire-box and the other to the ash-pit beneath the grate-bars  $C$ .

The operation of this part of the engine is as follows: As the piston  $V$  rises, carrying with it the air-pump piston  $x$ , the valves 4 and 1 are operated, and the valves 2 and 3 are closed, the air above the piston  $x$  passing through the hollow rod  $z$  to the interior of the piston  $V$ , up through the pipe  $Y$ , down through the pipe  $Z$  and passage  $x^2$  to the fire-box. At the same time that this is taking place, the valve 4 in the bottom of the air-pump is opened, and air enters beneath the piston  $x$ . On the descent of the pistons  $V$  and  $x$ , the valves 2 and 3 are opened and 1 and 4 are closed, and the air is forced through the chamber in the piston,  $V$ , as before to the fire-box, and thus a constant current of air is passed through the piston, by which any heat that may be conducted to it through the prolongation  $W$  is carried off, and it is kept so cool that the oil used for lubricating the piston is not destroyed or changed. The air is made to circulate more perfectly through the piston by the deflecting-plate  $C^2$ , Figs. 3 and 4.

In order to regulate the force with which the fire is urged to accord with the work upon the engine, the pipes  $d^2$  and  $f^2$ , one of which enters the fire-box above the fire and the other the ash-pit beneath the grate-bars, are furnished with valves 5 and 6, the rods 7 and 8 of which pass out through stuffing-boxes 9 and 10, and are manipulated by hand. When the upper valve is opened and the lower one closed, the air is all thrown above the fire, and, in proportion as the lower valve is opened, more air is admitted beneath the grate-bars and is passed through the fire, by which the fire is urged to a greater intensity. The working-piston is connected, by means of rods  $O^2$ , with the up-and-down beam  $D^2$ , that vibrates upon a standard,  $E^2$ , rising from the main cylinder, and from which the power is communicated by the connecting-rod  $F^2$  to the driving-shaft  $G^2$ , which carries the fly-wheel  $H^2$ .

For the purpose of regulating the speed of the engine, the following device is employed: One of the legs,  $i^2$ , Fig. 2, which supports the air-pump, has a passage through it, Fig. 2, which communicates with the interior of the air-pump and with a pipe,  $k^2$ , near to the outer end of which are one or more openings through which air from the pump is allowed to escape when the openings are not covered by the inclosing-sleeve  $m^2$ . This sleeve is operated by the governor-balls, which slide upon the arms  $e^2$ , projecting from another sleeve,  $q^2$ , which is prevented from moving longitudinally on the pipe  $k^2$  by collars 11 and 12. This sleeve, together with the sleeve  $m^2$ , is revolved upon the pipe  $k^2$  by a band or strap from the pulley  $m$  on the main shaft, running upon the pulley  $b^2$ , and thus, when the rate of motion of the engine exceeds the desired limit, the holes in the pipe  $k^2$  will be uncovered, and air will be permitted to escape, thus modifying the pressure within the fire-box and cylinder.

What I claim as my invention, and desire to secure by Letters Patent, is—

1. Lining the fire-box with fire-brick or their equivalent upon all sides, except the bottom, as set forth.

2. The parts or pieces of the fire-box  $G$  and  $H^2$ , in combination with the exterior casing,  $A$ , the space between them being filled with plaster or its equivalent, for the purpose specified.

3. The induction-pipes  $d^2$   $f^2$ , arranged and operating as described, in combination with the pipe or passage which brings the air from the air-pump to the furnace, for the purpose of regulating the intensity of the fire, as set forth.

S. H. ROPER.

Witnesses:

SAM. COOPER,  
P. E. TESCHEMACHER.