

E. BUCKUP.  
AIR ENGINE.

No. 7,470.

Patented July 2, 1850.

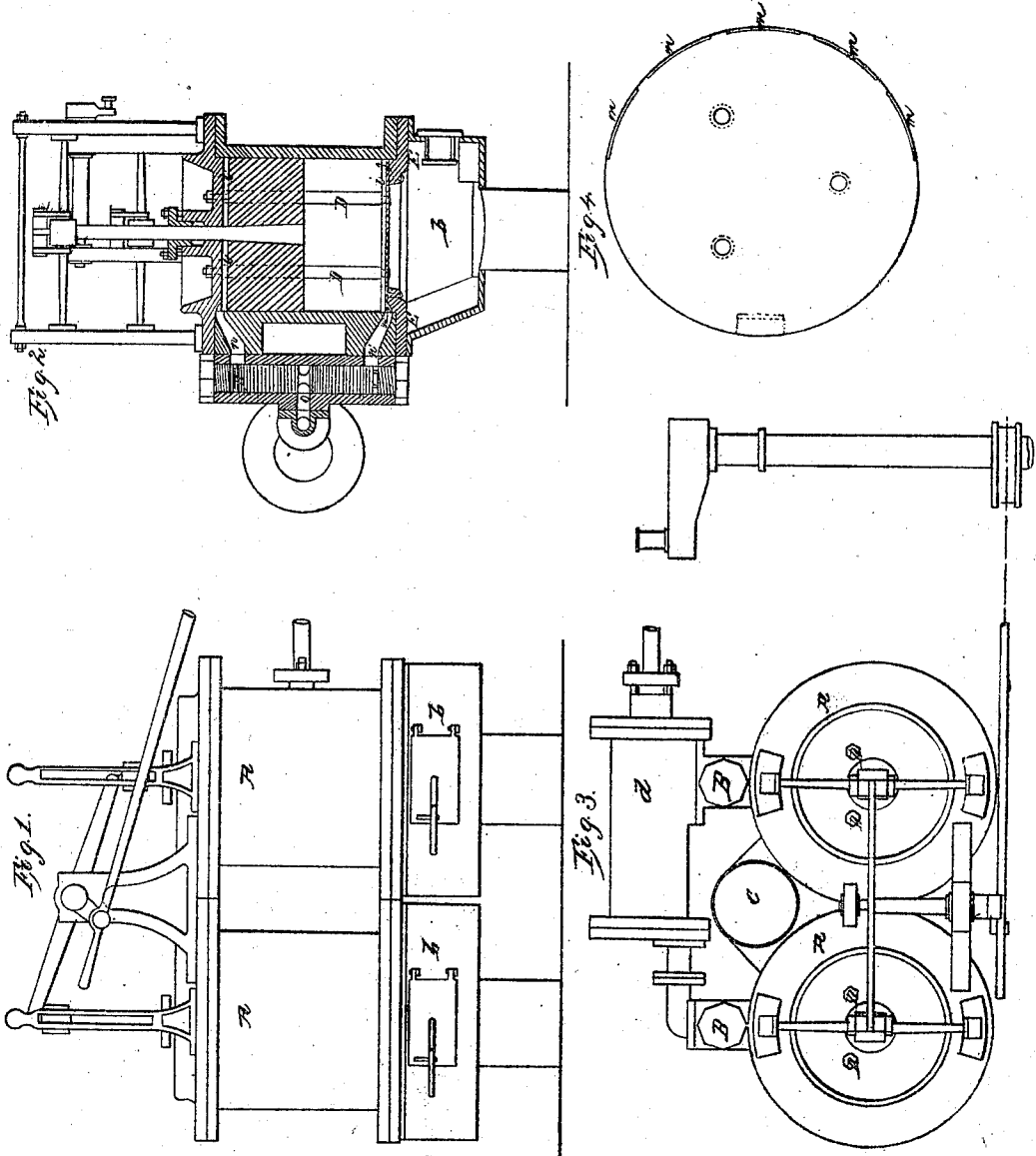

Inventor  
E. Buckup

# UNITED STATES PATENT OFFICE.

ERNST BUCKUP, OF NEW YORK, N. Y.

## METHOD OF DISTRIBUTING AIR OVER HEATING AND COOLING SURFACES OF AIR-ENGINES.

Specification of Letters Patent No. 7,470, dated July 2, 1850.

*To all whom it may concern:*

Be it known that I, ERNEST BUCKUP, of the city, county, and State of New York, have invented a new and useful Improvement in Air-Engines, and I do hereby declare the following to be a full, clear, and exact description of the same, reference being had to the annexed drawings, making a part of this specification, in which—

5 Figure 1 is a side elevation. Fig. 2 is a transverse section. Fig. 3 is a top view. Fig. 4 is a plan of one of the false bottoms of the hot-air cylinder.

10 Similar letters refer to similar parts in all the figures.

The nature of my invention consists in some improvements in hot air engines, whereby a greater economy of working is obtained, and also greater durability and efficiency are insured to the apparatus.

15 In air engines constructed on the old plan, the heat was brought in contact with the air cylinders, and the heat radiated directly upon the mass of air contained within the same; from this it was injected directly into the working cylinders at a high degree of temperature, and thus the packing of the pistons &c., was soon injured. The bottom of the hot air cylinder in contact with the fire was also soon destroyed by the alternate heating and cooling of the air. I remedy these defects by causing the air to be heated, to pass over the whole of the heating surface in a thin stratum, and thus a comparatively continuous current is maintained, and a more equal temperature of the heating plates insured, as will be more fully described.

20 In operating hot air engines the destruction of the packing, &c., in the working cylinder, from using the hot air at such high temperature, was soon made evident and in order to avoid this the air was subsequently used at a lower temperature; this however was done at the expense of power, for the air had not the same expansion, and therefore produced less effect. To remedy the first evil and yet avoid the second, I conceived the idea of attaching the working cylinders in such a way that the air would be used at a temperature between the two extremes and yet secure the economy consequent upon a high degree of heat. The following is the manner in which I attain these several ends.

25 A, A, represent two hot air cylinders hav-

ing their furnaces beneath at (*b, b,*) as in the ordinary manner, (*c*) being the flue or escape passage. The top of these cylinders is made dishing so that they can hold water (as shown in Fig. 2) and having in the center the usual stuffing box for the piston rod to pass through. The pistons in the hot air cylinders are connected by a beam which is worked from the crank shaft of the working cylinder (*d*) in the ordinary manner. The working cylinder is placed in a convenient position to be connected with the hot air cylinders.

30 The first of my improvements which I shall describe is that for preventing the injury to the top and bottom of the air cylinders by contractions and expansions. This I accomplish by affixing a second or false bottom and top to the inside. These are thin plates of metal one of which is shown at Fig. 4 and consists of a disk of the same circumference as the hot air cylinders themselves; at the opposite side from the apertures for admitting or ejecting the air, several narrow spaces are cut as seen at (*m*). The plates thus formed are put in the cylinder, and held in position by three or more stay bolts (*D*) so as to leave a narrow channel only between as shown) which bolts also serve to sustain the heads of the cylinders. As the piston ascends therefore, and the air to be heated rushes through the channel (*n'*) it is distributed in a thin stratum and thus sweeps over the whole bottom plate in contact with the fire and passes out through the apertures (*m*). After the piston has ascended to the top, the return forces the air back in the same way thus a prolonged action is insured and a greater effect in regard to heating the air also. The air is cooled on the same principle at the top passing through (*i*) and thus brought in contact with the cold surface of the top or head in the same manner as it is done on the hot plate at the bottom.

35 At the letter B is a chamber or pipe attached to the hot air cylinders so as to communicate with the upper and lower ports (*n, n,*' in the center or thereabout a branch pipe leads off and communicates with one end of the working cylinder, and from the same chamber on the other hot air cylinder another branch pipe leads off and connects with the opposite end of the working cylinder. The interior of this chamber B

is then to be filled with a series of thin plates (represented by the five horizontal lines in said chamber) of some good conducting metal said plates being perforated with numerous holes—these are placed one on top of the other, or instead of being laid in this way many narrow divisions or partitions-plates are inserted longitudinally to subdivide the air in very thin strata, or wire gauze or net work can be substituted. The use of this chamber thus constructed is as follows. As the heated air is sent out of the cylinder through this chamber it is passed through the holes in these plates which accordingly take up a considerable amount of heat and the temperature of the air is thereby reduced. About midway in the chamber B there is a space left in the series of perforated plates as seen at (o), from this place the branch pipe is connected which leads to the working cylinder. The air therefore by the time it arrives at this place has been sufficiently reduced in temperature to be admitted into the working cylinder, without injury to its moving parts. The whole charge of hot air having been given in exhausting it from the working cylinder it is passed on up into the upper

part of the hot air cylinder through (n) where it is cooled by the plan before described. The return stroke of the engine brings this air back through B to be charged again with heat as before but in passing through B the air now takes up the surplus heat imparted before to the perforated plates which is thereby saved.

My improvement therefore consists in applying the inner plates (*i, i'*) to the hot air cylinders to insure a more equal distribution of the heat and also by causing a current to pass over the heating and cooling surfaces the liability to injury is greatly lessened.

What I claim as of my own invention and desire to secure by Letters Patent is:

Causing the air entering and leaving the cylinder to pass over the heating and cooling surfaces in a thin stratum by means of the plates (*i, i'*) or their equivalents, substantially in the manner and for the purpose set forth.

ERNST BUCKUP.

Witnesses:

S. H. MAYNARD,  
THOMAS H. WOOD.